

BUG SCREEN SIZE	OUTSIDE DIAMETER (MM)
1"	108
2"	152
3"	191
4"	229
5"	254
6"	279
8"	343
10"	406
12"	483

No:	Nosi:	Description	Material:
A	1	PERFORATED SCREEN 2MM THICKNESS	ASTM A240 GR. TP316L
B	1	PLATE	ASTM A240 GR. TP316L

SCALE (2:1)

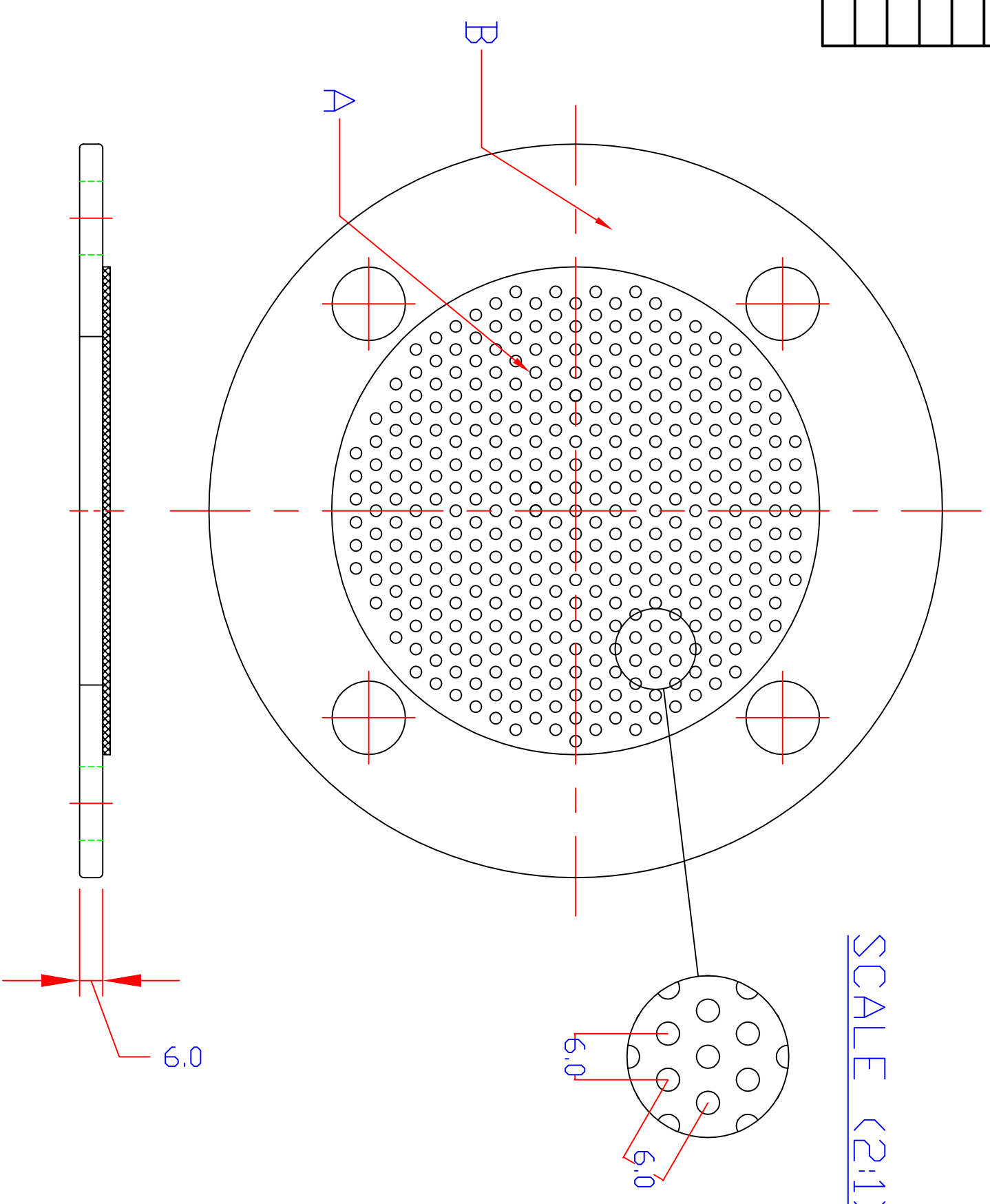

- NOTES:
1. ALL DIMENSION IN 'mm' UNIT
 2. DESIGN PRESSURE : 1 ATM Bar/g
 3. DESIGN TEMPERATURE : 60°C
 4. PERFORATED METAL SHEET 3 mm (0.125") HOLE DIAMETER, 40% OPENING HOLE SHALL BE STAGGERED THICKNESS OF PLATE GAUGE 14.

REV	DATE	DESCRIPTION	REVISION

VENDOR:

SHIN-YO ENGINEERING SDN BHD (INCORPORATED)
 No.6, Jalan Mega Mendung, Bandar Park, DfF Jalan Kelang
 Loma, 58200 Kuala Lumpur, Fax: 603-782 3383
 Tel: 603-794 8401

DATE:	DATE:	DATE:	DATE:	DATE:

ITEM:

BUG SCREEN

DRAWING NO: SY-GAD-SAMPLE

SCALE: 1:1

REV: A