

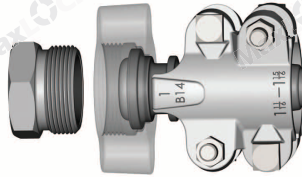



**MaxLOCK®**  
**GROUND**  
**JOINT**



**Features:**

- Positive metal-to-polymer seal
- Leakproof seal forms when the metal head of the stem makes contact with the patented polymer seat in the spud
- Non-metallic polymer seat resists most chemicals found in manufacturing facilities
- Recommended for steam service up to **450°F (232°C)**
- Easy to seal
- Use with Maxlock® clamps

| MAXLOCK GROUND JOINT FEMALE NPT ADAPTERS (MG-FA)                                   | SIZE        | OPTIONAL QTY |
|--|-------------|--------------|
|  | 1/4"        | 100          |
|  | 3/8"        | 100          |
|  | 1/2"        | 100          |
|  | 1/2" x 3/4" | 50           |
|  | 3/4"        | 50           |
|  | 1"          | 50           |
|  | 1 1/4"      | 25           |
|  | 1 1/2"      | 25           |
|  | 2"          | 10           |
|  | 2 1/2"      | 5            |
| 3"   | 5           |              |
| 4"   | 5           |              |
| 6"   | 2           |              |

\* supplied with wing nut, as shown.  
 \*\* design to fit the Maxlock® Ground Joint Female Spuds.  
 \*\*\* part is produced as a welded fabrication.

**PART NUMBER**



| MODEL                                   | PART NO. | MATERIAL            | COUPLING SIZE      |
|---|----------|---------------------|--------------------|
| <b>MG</b><br>Maxlock<br>Ground<br>Joint | JS       | <b>PS</b>           | <b>8</b> = 1/4"    |
|   | JC       | Plated Steel        | <b>10</b> = 3/8"   |
|   | WN       | <b>SS</b>           | <b>15</b> = 1/2"   |
|   | FS       | Stainless Steel 316 | <b>20</b> = 3/4"   |
|   | MP       |                     | <b>25</b> = 1"     |
|   | DS       | <b>BR</b>           | <b>32</b> = 1-1/4" |
|   | FA       | Brass               | <b>40</b> = 1-1/2" |
|   | MA       |                     | <b>50</b> = 2"     |
|   | MS       |                     | <b>65</b> = 2-1/2" |
|   |          |                     |                    |
|   |          |                     | <b>100</b> = 4"    |
|   |          |                     | <b>150</b> = 6"    |